



Twilight^{V2} VFD

The Twilight range offers unrivalled performance, utilising the latest low light Sony image processors...

PRODUCT FEATURES:

- Sony HQ1 540 TVL, Sony DSP
- Strong IR Illuminators **30M** IR
- Vari-focal 4-9mm auto iris lens
- Split Glass Technology
- Extremely Clear images in Low Light. 0 Lux



water resistant



weather proof



double glass



day/ night



infra red



night vision



vandal proof

DIMENSIONS

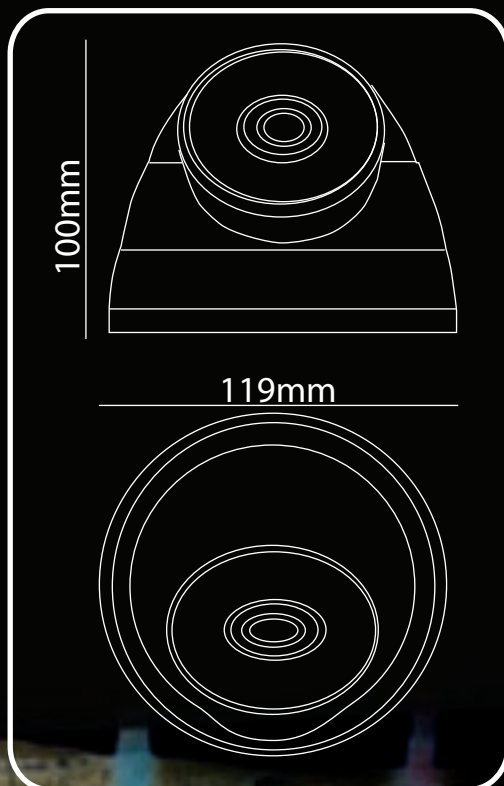

SPECIFICATION

Model	TWILIGHT FLD
Image Processor	SONY
Imaging device	SONY1/3"
CCDType	1/3"SONY CCD
Pixels	PAL:795x596
Horizontal Resolution	540TVL
TV System	PAL
Level Synchronization frequency	PAL:15.625KHZ
Clock frequency	PAL:19.3125
Scanning frequency	2:1 interlace
Minimum illumination	0.1LUX (IR on)
Sync.System	internal Synchronization
S/N Ratio	48 dB
Electronic Shutter	PAL:1/50-1/100,000sec
Gamma Correction	0.45
Video Output	1 Vpp,75 Ohms
AGC	Auto
Night vision	36pcs(30m)
Power supply	12VDC(+/-10%)
Current	400mA
Dimensions	119*100mm
Weight	0.62Kg
Operating temperature	-10-45°C
Colour	Dark Gray

'A Versatile High Performance Fully Adjustable Vandal Dome'